



ATD-8400

BENCH TOP BLAST CABINET INSTRUCTION MANUAL

Thank you for purchasing the ATD Bench Top Blast Cabinet,
designed for professional workshop use.

Please read this booklet thoroughly and follow the instructions carefully to ensure the safety of yourself of others around you and to be sure that you can look forward to the Bench Top Blast Cabinet giving you long and satisfactory service.

WARRANTY

This ATD product is warranted against manufacturing defects for a period of 12 months from the date of purchase. Please keep your receipt as proof of purchase. This warranty is invalid if the product is found to have been abused or tampered with in any way, or not used for the purpose for which it was intended.

Faulty goods should be returned to their place of purchase. No product can be returned to us without prior permission.

This warranty does not affect your statutory rights.

FEATURES

The ATD 2.5 CU. FT. Bench Top Blast Cabinet is lit by a low voltage (12 volt) fluorescent tube. An AC power adapter is provided and should be plugged directly into any 120v wall outlet. The attached cable is then plugged into the switchbox, mounted on the left side of the cabinet. The switchbox contains the ON/OFF rocker switch.

We strongly recommend that this unit be used with a vacuum extraction device. Air is extracted via a double filtration system from the opening at the right hand side of the cabinet.

Please note that when vacuum extraction is used, air will be drawn into the cabinet through the hole on the back panel of the unit.

If vacuum extraction is **NOT** used, the hole must be covered on the outside with a foam filter that must always be in place to prevent grit from being blown out.

The lid contains two clear plastic windows, the inner of which may be replaced quickly and easily if it should become damaged by the sand blasting action.

A variety of abrasive nozzles are supplied with the unit to produce a useful range of power and grit densities to satisfy all requirements. **The cabinet is designed for use with dry abrasives only.** We recommend Aluminum Oxide (for cleaning steel) and Glass Beads (for cleaning Aluminum).

It is necessary to provide a clean, dry air supply, capable of delivering a minimum of 10cuft/min at 100lbf/in². Please consult your air compressor manual, to be sure that you comply with all safety precautions regarding the use of air compressors and observe all necessary precautions when using compressed air.

SAFETY PRECAUTIONS

1. Be sure that you comply with all precautions concerning the use of air compressors and compressed air.
2. Be sure all air connections are secure.
3. **DO NOT** use the machine if the rubber gloves are ripped or otherwise unserviceable.
4. Be sure the clear plastic lid is firmly secured before pressing the trigger.
5. Keep the jet well away from the air inlet hose (from side panel to gun).
6. **ALWAYS** wear safety glasses. (Normal eyeglasses are **NOT** safety glasses).

ASSEMBLY

Carefully unpack the unit and check to ensure that no damage was caused in transit. Should any damage be apparent, please contact your ATD dealer immediately. Remove all components from inside the cabinet and check them against the following list.

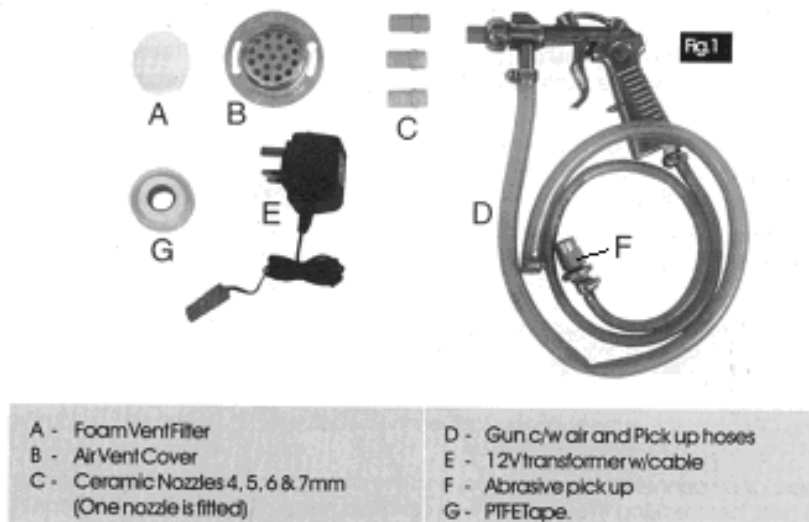

The unit is shipped completely assembled, except for the air vent filter and the gun and its attached hoses. These should be connected as follows:

First, remove the grid (#1) and all the various components from within the cabinet. The end of the air inlet hose, connected to the gun, is inserted through the 16mm dia. hole in the cabinet, from the inside, as shown in Fig 2. Be sure a flat washer is used on the adapter as shown.

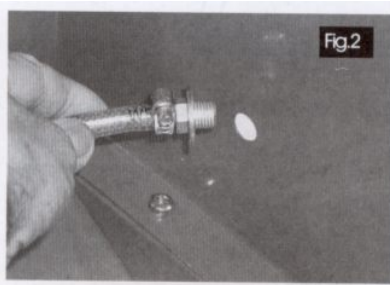

Place a flat washer, followed by the extended nut, on to the adapter, from the outside of the cabinet and tighten.

The abrasive pickup fitting (item# 33) is already attached to the end of the pick-up hose which is connected to the gun. Take the nut and washer off of the fitting, then insert the fitting through the hole at the bottom of the cabinet from the **inside** of the cabinet. Then, from the **outside** of the cabinet, place the flat washer over it and secure with the nut. Both the washer and nut were originally attached to the pickup fitting.

Insert the circular foam filter (#20) into the recess in the Air Vent Cover and attach the cover to the rear of the cabinet as shown in Fig 3, having first pressed out the plastic bung from the vent hole.



Finally, connect the air supply to the extended nut shown in Fig 4.
Use the PTFE tape supplied to ensure an airtight seal.

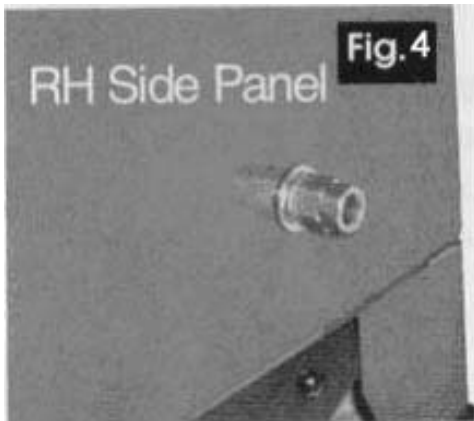

The air supply should be dry and capable of delivering a minimum of 10cuft/min at 100lbf/in².

OPERATION

Plug the AC power adapter into the wall outlet and switch the power ON.
(Switch the lamp ON by pushing "I", switch OFF by pushing "O".)

Be sure that all air connections are secure and the pick up is correctly located beneath the grid before filling the cabinet with abrasive media. Do not fill higher than the level of the grid.

NOTE:

PTFE tape is provided. Use it on the threads of the various connectors to ensure an airtight connection.

Select the ceramic abrasive nozzle to produce the jet required for the abrasive media being used and assemble according to the instructions given below in figure 6.

Place the object to be cleaned in the cabinet and close the lid, secure the lid with the two swivel clips.

If you are using a vacuum extraction device, turn it on before turning on the air supply. Set the pressure to the required value, but not higher than 100lbf/in² and check to be sure there are no air leaks. Should there be any; turn off the air supply and repair where necessary, before turning the air supply back on. Pull the trigger on the gun and proceed to blast the object to be cleaned.

Keep the jet facing the object and away from the clear plastic lid. Do not allow the jet to contact the rubber gloves, the air hose, or the fluorescent lamp.

When completed, turn off the air supply first and as a precautionary measure, pull the trigger before opening the lid to be sure that the air supply is off.

NOTES:

There are no hard or fast rules governing nozzle sizes and air pressures used with different abrasives. With experience and experimentation you will quickly learn the best combinations for the required result.

On more delicate parts, start with minimal air pressure to avoid unnecessary pitting or excessive abrasion, and work up to a setting to produce the desired finish.

Should any abrasive be spilled, be sure that it is cleaned up immediately, as it is slippery, and can be extremely hazardous.

REPLACING THE ABRASIVE NOZZLE

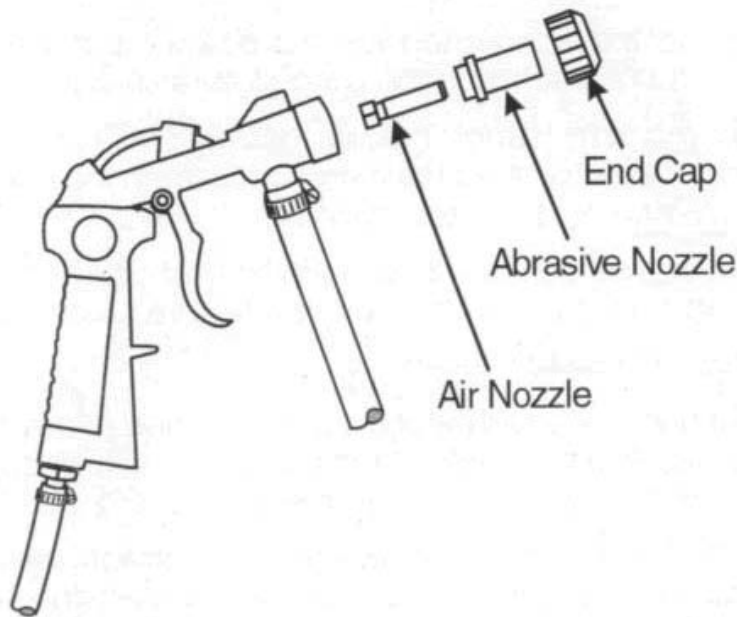

Fig.5

Be sure the air supply is disconnected before performing this operation.

1. Pull the trigger of the gun as a precautionary measure, to be sure that the air supply is off.
2. Unscrew the end cap and take out the ceramic nozzle.
3. Replace with the nozzle of your choice and carefully thread the end cap back on to the gun, taking great care **NOT** to cross thread the fine thread.

NOTE:

Should it be necessary to change the air nozzle, first remove the abrasive nozzle as described above. A wrench will be required to unscrew and remove the air nozzle.

MAINTENANCE

Before use, check that all parts are serviceable, including the air inlet hose, rubber gloves and abrasive pick-up.

Be sure that the air vent foam filter is in place.

The swivel clamps, securing the lid, must be secure so as not to allow the lid to open during operation. The build up of air pressure within the cabinet could force the lid open, allowing abrasive to escape. This is not only wasteful but could be a health hazard.

Be sure that the filters are serviceable and seated correctly.

Be sure you comply with all precautions regarding the use of compressed air and air compressor operation.

CHANGING THE FLUORESCENT TUBE

Disconnect the AC power adapter from the power supply before proceeding.

Open the lid and cut the two ties securing the lamp to its retaining clips. Carefully pull the lamp from its retaining clips then hold the clear plastic protective outer tube firmly and carefully ease off the plastic end cover from the non-wired end.

Once the end cover has been removed, hold the end cover at the opposite end (the cable input end), and pull off the outer protective clear plastic tube.

The fluorescent tube is now fully revealed.

Pull off the end connector, which secures a wire to one of the pins, taking care not to damage the aluminum reflector. Then pull off the wire secured by a plastic sheath to one of the pins at the cable input end.

Assemble in reverse order, ensuring that the plastic sheath at one end and the end connector at the other correctly hold the wires, with the reflector correctly in position.

Replace the assembly into its retaining clips and test its operation by plugging in the transformer and turning the lamp on.

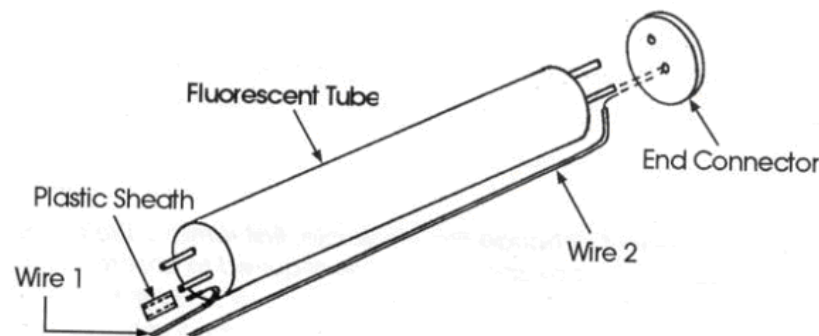

TROUBLESHOOTING

PROBLEM	CAUSE	REMEDY
Excessive dust in cabinet	Air vent or airflow is blocked Abrasive media worn Too much abrasive media in the cabinet Loose air line or fitting connections	Clean rear vent, and keep vent away from any wall Replace abrasive media Remove excessive media Tighten fittings and make sure air lines are secure.
Uneven blasting action	Too much abrasive media inside cabinet Abrasive is damp Moisture present inside cabinet	Remove excessive media Renew abrasive or dry thoroughly before use. Check air line to ensure it is free from moisture
Inadequate speed or inefficient blast	Abrasive media worn Pressure too low	Replace abrasive media Increase inlet pressure and ensure control valve is fully opened
Static electricity present	Dry weather conditions	Leave the item to be cleaned on the grid
Excessive Media blown into surrounding atmosphere when no vacuum extraction is being used	Lid not secure Air vent filter missing	Secure lid with swivel clips and adjust them if necessary. Replace filter or block off hole in rear panel temporarily with masking tape. (Remember to remove masking tape when using vacuum extraction.)

SPECIFICATIONS:

Model:	ATD-8400
Weight:	40lbs
Overall Dimension:	19" x 26"x 19"
Working Area:	18" x 22"x 11"
Air Pressure:	100PSI
Abrasive Capacity:	30 pounds
Air Inlet Size:	1/4" NPT
Hose Size:	1/4"
Nozzle Size:	5/32" (4mm); 13/64"(5mm); 15/64"(6mm); 17/64"(7mm)
Power Adapter:	120VAC/12VDC lamp power supply
Features:	Trigger Operated Includes: 12VDC Fluorescent Lamp, Blasting Gun, Gloves and Screen



ATD-8400

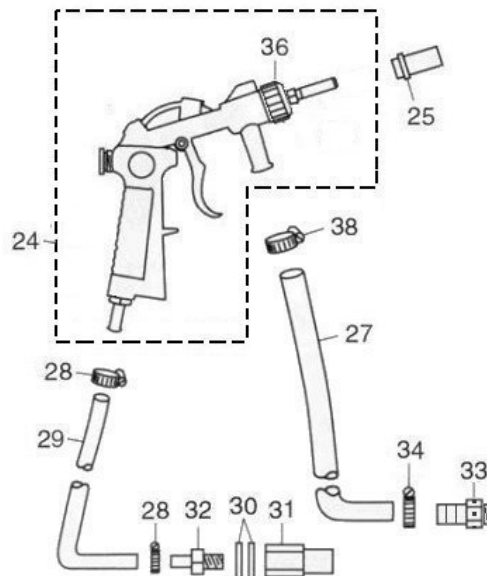
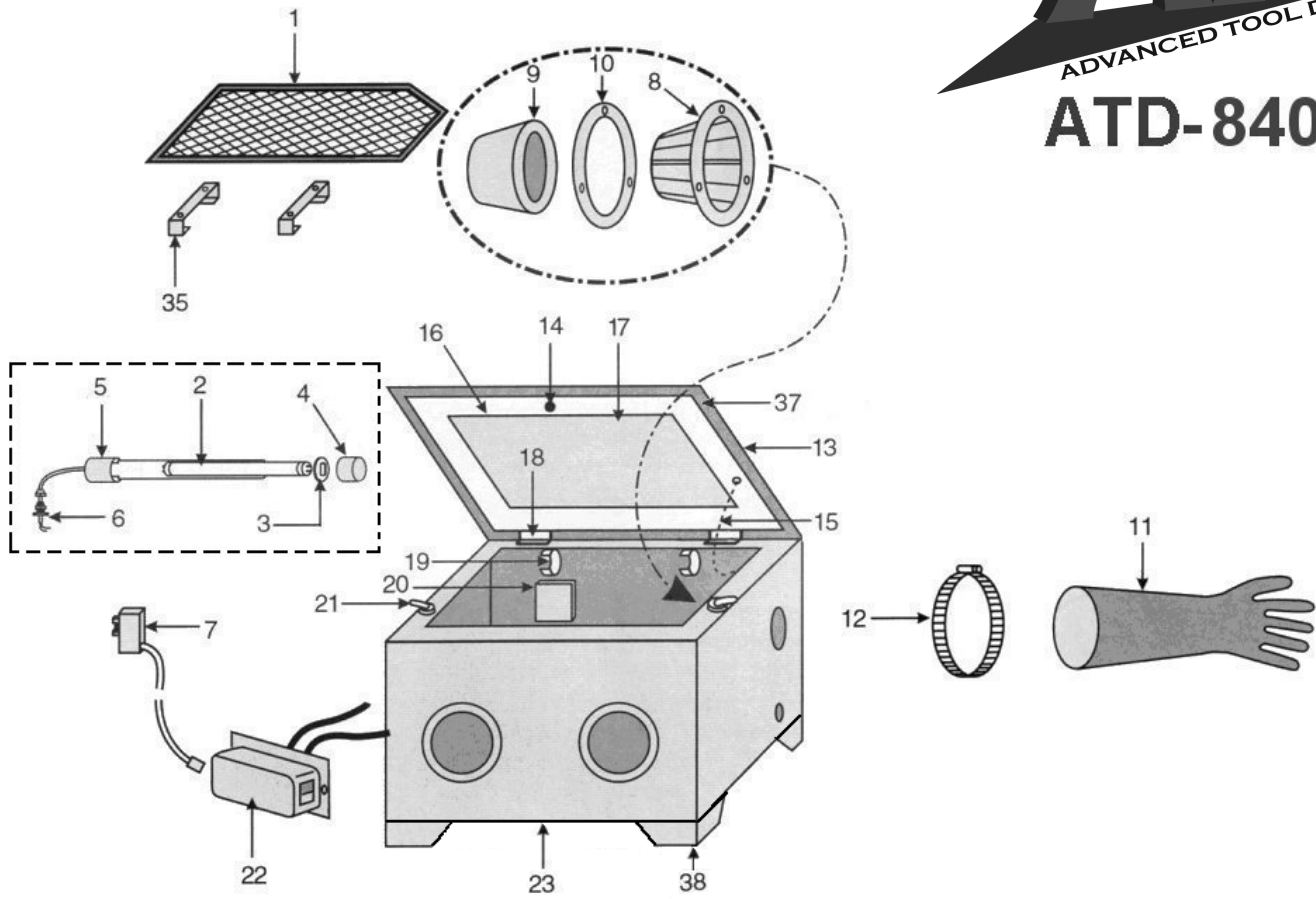

ITEM#	ORDERING PART#	PART DESCRIPTION
1	PRT8400-01	GRID
2-5	PRT8400-02-05	LIGHT ASSY (BULB, WIRING, PLASTIC END COVER, REFLECTOR)
6	PRT8400-06	CABLE GLAND ASSEMBLY
7	PRT8400-07	AC POWER ADAPTER
8	PRT8400-08	MAIN FILTER
9	PRT8400-09	SECONDARY FILTER
10	PRT8400-10	RETAINING DISC
11	PRT8400-11	RUBBER GLOVES (PAIR)
12	PRT8400-12	HOSE CLAMP
13	PRT8400-13	LID FRAME
14	PRT8400-14	KNOB
15	PRT8400-15	LID RETAINING CHAIN
16	PRT8400-16	CLEAR PLASTIC WINDOW
17	PRT8400-17	WINDOW UNDERLAY
18	PRT8400-18	LID HINGE
19	PRT8400-19	FLORESCENT TUBE CLIP
20	PRT8400-20	AIR VENT FOAM PACKING
21	PRT8400-21	LID SWIVEL CLAMP
22	PRT8400-22	CABLE CONNECTION BOX
23	PRT8400-23	CABINET ONLY (WITHOUT LID)
24	PRT8400-24	GUN (INCLUDES END CAP AND AIR NOZZLE)
25	PRT8400-25-4	ABRASIVE NOZZLE 4MM
25	PRT8400-25-5	ABRASIVE NOZZLE 5MM
25	PRT8400-25-6	ABRASIVE NOZZLE 6MM
25	PRT8400-25-7	ABRASIVE NOZZLE 7MM
27	PRT8400-27	ABRASIVE INTAKE HOSE
28	PRT8400-28	HOSE CLAMP
29	PRT8400-29	AIR HOSE
30	PRT8400-30	FLAT WASHER
31	PRT8400-31	ADAPTER NUT
32	PRT8400-32	ADAPTER
33	PRT8400-33	ABRASIVE PICKUP
34	PRT8400-34	HOSE CLAMP
35	PRT8400-35	GRID FOOT
36	PRT8400-36	END CAP
37	PRT8400-37	LID SEAL
38	PRT8400-38	LEG